

REVERSIBLE CONCRETE MIXER



Technical data						
BIO		500S	750S	500B	500BD Compact	750BD Compact
Output	kg	350	250	350	350	500
Drum Capacity	Lt.	500	750	500	500	750
Revel./min	rpm	18	16	18	18	18
Elect. motor	HP	5,5	10	5,5		
Diesel engine	HP				15	20
Weight	kg	1150	2170	1240	1260	1820

TRADEHOUSE International A/S
Poppelgaardvej 7, DK 2860 Soborg
Tel: +45 3966 1866, Fax: +45 3966 1065
info@tradehouse.dk
www.tradehouse.dk

Turn over

BIO MODEL B

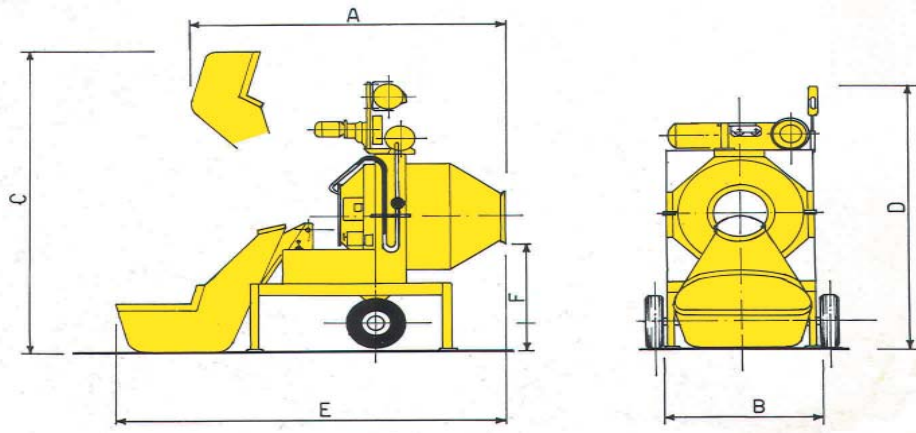

BIO MODEL S

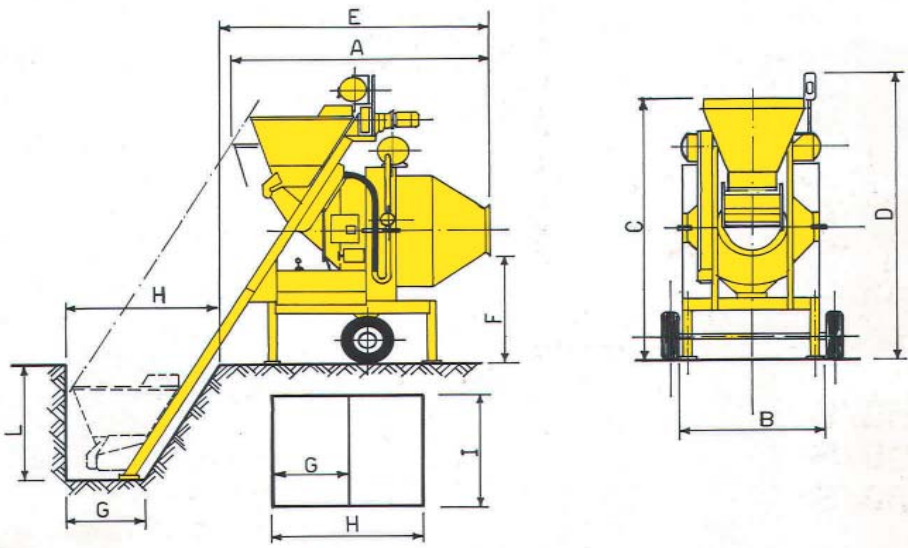

Technical Data Model B				
	BIO	500B	5000BD Compact	750BD Compact
A	mm	2680	2680	2900
B	mm	1380	1380	1700
C	mm	3050	3050	3300
D	mm	2840	2840	2980
E	mm	3580	3580	3900
F	mm	1210	1200	1210

Technical Data Model S			
	BIO	500S	750S
A	mm	2680	2900
B	mm	1380	1700
C	mm	3050	3300
D	mm	2840	2980
E	mm	3580	3900
F	mm	1210	1210
G	mm	900	900
H	mm	1500	1700
I	mm	1500	1700
L	mm	1200	1300