





Designation	Identification	No. of pages
Preventive maintenance	5606-00	5
General hints lube oil	4634-01	1
Winches	5608-00	4
Lubrication of slewing bearing ring	5413-00	1
Hook, Pulleys	5346-00	1
Slewing brakes, greasing	C4-16.00045720-00	1
Crane ropes	1970-00	3
Lubrication chart	2300-02	1
Lubricants	2102-11	2

PREVENTIVE MAINTENANCE SCHEDULE			OPERATION TIME IN HOURS							KRÖLL CRANES A/S	
SLEWING		ASSEMBLY DRAWING	50	100	200	500	1000	2500	5000		
ITEM No.	CATE-GORY	LOCATION	MAX. PERIODS IN WEEKS							MAINTENANCE/REPAIR INSTRUCTION REF.	
			1	2	4	12	26	52	100	INFO REF.	NOTES
1	E	11.5 kW - AC MOTOR	V								Ref. Equipment manuals
2	M/E	BRAKE			V					16.00045720	Ref. Maintenance
3	M	AIR-GAP CHECK			V						Ref. Maintenance
4	M	GEAR UNIT			V						Ref. Equipment manuals
		OIL LEVEL AND CHANGE			V			R			First change of oil after 300 operation hours
5	M	OPEN GEARS	V/L							5413-00	Enclosed
7	M	SLEWING RING BOLTS	V							2267-00	Ref. Service
8	M	MESSUREMENT OF BEARING PLAY					T			2277-07	Ref. Service
9	E	ELECTRICAL CABLES			V						
10	M/E	COLLECTOR	V								
		BRUSH CHECK					T				
 M = Mechanical E = Electrical			V = Visuel/hand-check/inspection/cleaning/Loose fixing elements etc. T = Maintenance check with required tools R = Replace L = Oil when necessary								

PREVENTIVE MAINTENANCE SCHEDULE			OPERATION TIME IN HOURS							KRÖLL CRANES A/S	
HOIST WINCH		ASSEMBLY DRAWING	50	100	200	500	1000	2500	5000		
ITEM No.	CATE-GORY	LOCATION	MAX. PERIODS IN WEEKS							MAINTENANCE/REPAIR INSTRUCTION REF.	
			1	2	4	12	26	52	100	INFO. REF.	NOTES
1	E	42.5 kW - AC MOTOR WITH BRAKE	V								Ref. Equipment manuals
2	M/E	COOLER			V			T			
		FILTER				V	T				
3	M	GEAR UNIT									Ref. Equipment manuals
		OIL LEVEL	V/L								First change of oil after 400 operation hours
4	M	HOIST ROPE			V/L					1970-00	Enclosed
5	M	FLANGE BEARING			V/L						
6	M	BOLTS CONNECTION FOUNDATION FRAME			V		T				
7	E	END STOP SWITCH AND CABLES			V						
 M = Mechanical E = Electrical			V = Visual/hand-check/inspection/cleaning/Loose fixing elements etc. T = Maintenance check with required tools R = Replace L = Oil when necessary								

PREVENTIVE MAINTENANCE SCHEDULE			OPERATION TIME IN HOURS							KRÖLL CRANES A/S	
TROLLEY WINCH		ASSEMBLY DRAWING	50	100	200	500	1000	2500	5000		
ITEM No.	CATE-GORY	LOCATION	MAX. PERIODS IN WEEKS							MAINTENANCE/REPAIR INSTRUCTION REF.	
			1	2	4	12	26	52	100	INFO. REF.	NOTES
1	E	6 kW - AC MOTOR	V								Ref. Equipment manuals
2	M	GEAR UNIT			V						Ref. Equipment manuals
		OIL QUANTITY AND LEVEL			V			R			
		BOLTS			V			T			
3	M	TROLLEY ROPE AND WEDGES/DRUM			V					1970-00	Enclosed
4	M	BOLTS CONNECTION, FLANGE BEARING FOUNDATION FRAME			V			T			
5	E	END STOP SWITCH AND CABLES			V						
 M = Mechanical E = Electrical			V = Visual/hand-check/inspection/cleaning/Loose fixing elements etc. T = Maintenance check with required tools R = Replace L = Oil when necessary								

PREVENTIVE MAINTENANCE SCHEDULE			OPERATION TIME IN HOURS							KRØLL CRANES A/S	
STEEL STRUCTURE, BOLTS, MISC.PARTS			50	100	200	500	1000	2500	5000	MAINTENANCE/REPAIR INSTRUCTION REF.	
ITEM No.	CATE-GORY	LOCATION	MAX. PERIODS IN WEEKS							INFO. REF.	NOTES
			1	2	4	12	26	52	100		
1	M	STRUCTURE BOLT CONNECTIONS: UNDERCARRIAGE/PORTAL/ MAST/SLEWING/TOP TOWER/JIB/COUNTERJIB AND STAY BAR			V					2363-02 5281-01 5498-02	After the first 100 hours of operation.
2	M	MAIN STRUCTURE WELDING				V					Check for cracks
3	M	MAIN STRUCTURE				V					Check for damage, bent members etc.
4	M	COTTER PIN BOLTS				V/T					
5	M	SPEC. BOLTS OR AXLES				V		T			
6	M	PULLEYS (SEALED BEARINGS)				V					
7	M	SWIVELS/HOIST- & TROLLEY ROPE CONNECTION			V/L			T			
8	M	COUNTERWEIGHT & BALLAST BLOCKS					V				
9	E/M	MOMENT & MAX. LOAD DEVICES			V		T				See also test loading
10	E	SEALED SWITCHES					V/T				Incl. light lube & contact inspection
11	E	FEEDER CABLE AND TERMINAL BOXES					V				
12	M	LADDER SYSTEM/MAIN HOIST FITTINGS AND BOLTS				V					
 M = Mechanical E = Electrical			V = Visual/hand-check/inspection/cleaning/Loose fixing elements etc. T = Maintenance check with required tools R = Replace L = Oil when necessary								

PREVENTIVE MAINTENANCE SCHEDULE			OPERATION TIME IN HOURS							KRÖLL CRANES A/S	
TROLLEY & HOOK SYSTEM			50	100	200	500	1000	2500	5000		
ITEM No.	CATE-GORY	LOCATION	MAX. PERIODS IN WEEKS							MAINTENANCE/REPAIR INSTRUCTION REF.	
			1	2	4	12	26	52	100	INFO. REF.	NOTES
1	M	TROLLEY WHEELS		V							
2	M	HOIST ROPE PULLEYS		V							
3	M	TROLLEY ROPE CONNECTIONS		V							
4	M	TROLLEY ROPE STRAINER DEVICE		V/L							
5	M	HOOK BLOCKS & HOOKS		V							
6	M/E	INNER PULLEY PARKING SWITCH AND PAWL LOCKING DEVICE	V								
7	M	LINE PART CHANGE OVER SYSTEM		V							
8	M	LUBRICATION		L							
 M = Mechanical E = Electrical			V = Visual/hand-check/inspection/cleaning/Loose fixing elements etc. T = Maintenance check with required tools R = Replace L = Lube when necessary								



## GENERAL HINTS

Constant readiness for operation and high life requires regular and conscientious lubrication. Prior to crane assembly effect the necessary oil change. We request that the following are complied with in detail:



### **Danger!**

For lubrication and maintenance operation also conform to protective and accident prevention regulations and comply with the valid special regulations at the respective jobsite. Take the crane out of operation. Secure danger areas at, and in the slewing crane (an unintentional taking into operation of the crane mustn't be possible).

**Used oil** must be disposed of, according to the local regulations.

### **Lubrication points and lubrication periods:**

Under particularly heavy loading, severe dusty or very wet conditions, it may be necessary to maintain the crane more frequently than stated in the lubrication instructions. The enclosed lubrication instructions provide an overview of all lubrication points, filling quantities and the associated lubricants and lubrication periods. The following is of interest for the lubrication points.

### **Roller bearings:**

All roller bearings except for the bearings in the gearboxes are provided with grease filling at the factory. Under normal operation, it is sufficient to check the bearings every six months. The roller bearings of rope pulleys and rollers without possibility of lubrication have permanent life lubrication for maintenance-free operation.



### **Attention!**

The lubrication of the ball bearings requires special care. Here we urgently request that the lubrication and maintenance instructions for the ball bearing are complied with. Separate lubrication and maintenance instructions are also binding for the electric motors.

### **Gears:**

Most gears are filled with oil at the factory. The oil should be changed according to the maintenance schedule. Use only the prescribed quality oils. Oils with different basic oils mustn't be mixed with one another (e.g. mineral oil with synthetic oil). If large grain abrasion (more than 25 µm) or flashes of material of the gear flanks are ascertained, the gear must be generally checked by visual inspection. The gear must be generally overhauled in the case of features such as scores, seizing, formation of pits, flaking, cracks and plastic deformations of gear wheels.

### **Ropes:**

Regular maintenance and good lubrication increase life. At least as soon as bare places show, lubricate with oils specified for this, the total length of the ropes. The lubrication instructions of the rope manufacturer must be complied with for the ropes.

For all other lubrication points we request you to comply with the lubrication and maintenance instructions.



### **Danger!**

Only take a ready for service crane into operation (covers and protection devices must be installed).

## HOIST WINCH

Type of oil and quantity: See page 4

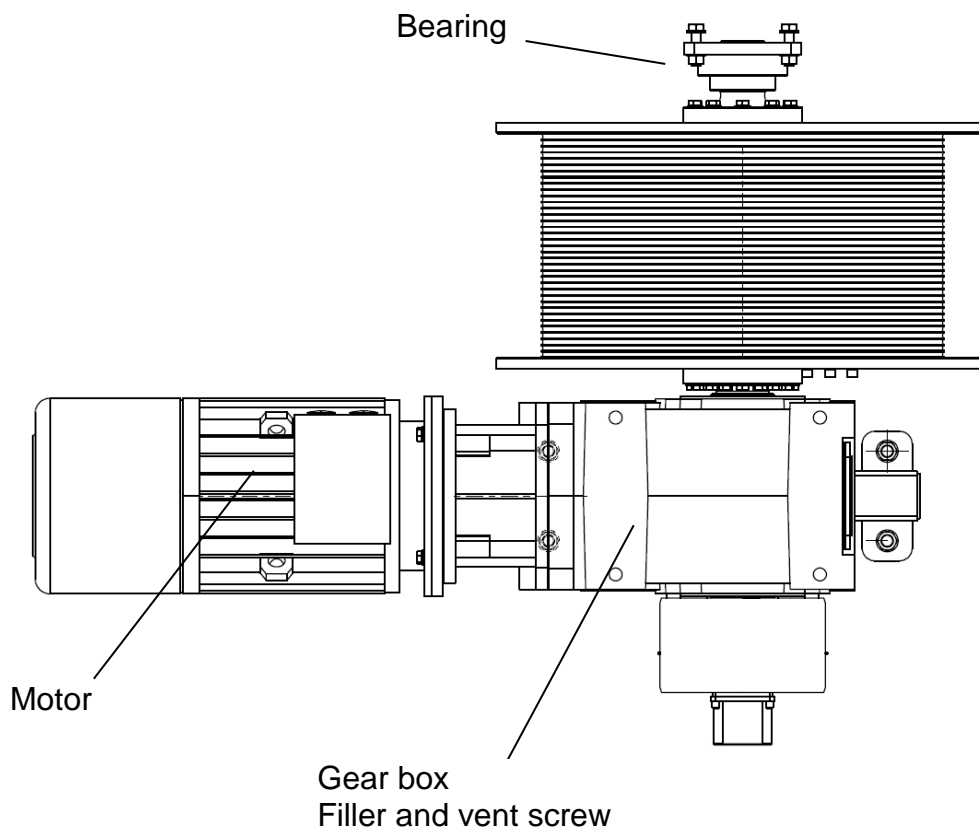

## GEARBOX

- Regular oil level check.
- Extreme working conditions (high air humidity, aggressive media and large temperature variations call for reduced lubricant changing intervals.

▽ Synthetic and mineral lubricants must not be mixed either for filling or for disposal!



## TROLLEY WINCH

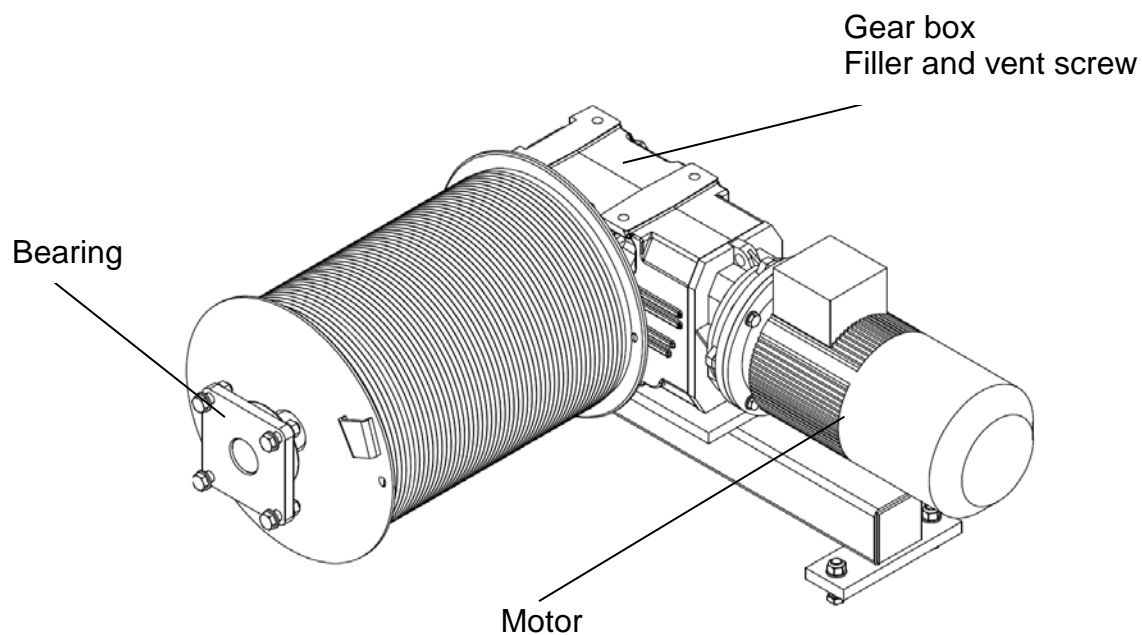

- Regular oil level check.
- Extreme working conditions (high air humidity, aggressive media and large temperature variations call for reduced lubricant changing intervals.

▽ Synthetic and mineral lubricants must not be mixed either for filling or for disposal!

## SLEWING MACHINERY

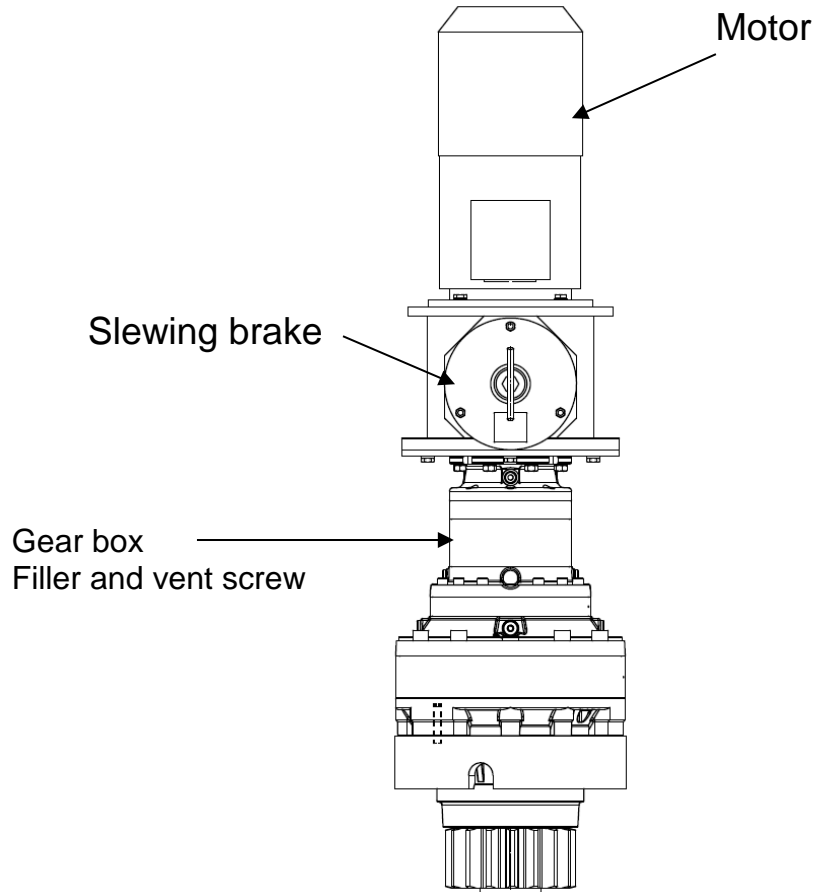

- Regular oil level check.
- Extreme working conditions (high air humidity, aggressive media and large temperature variations call for reduced lubricant changing intervals).

▽ Synthetic and mineral lubricants must not be mixed either for filling or for disposal!

**APPROXIMATE QUANTITY OF OIL / GREASE LIST**

Location	Approx. Quantity (litres)	Number of units	Note
Hoist winch gear	31	1	ISO-VG220
Trolley winch gear	3.9	1	ISO-VG220
Slewing gear	7.3 each	2	ISO-VG220
Open gear		1	Castrol MOLUB-Alloy 936 or similar
Bearings, pulleys			Shell Alvinia EP2 or similar

## LUBRICATION OF SLEWING BEARING RINGS

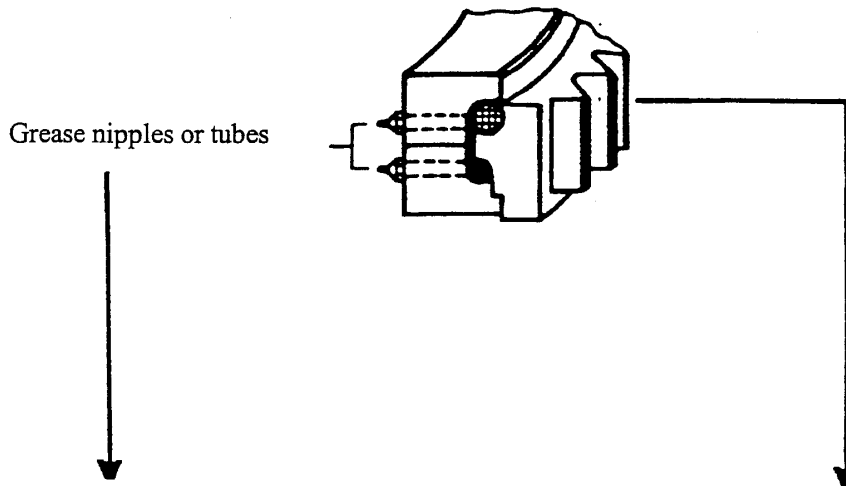

**THE BEARING** is to be greased with Shell Alvinia EP2 or similar.

**THE TEETH** should normally be greased with ELKALUB GL 10/N or similar every 10 hours' operation or, alternatively, a minimum of twice of week.

Under no circumstances may molybdenum disulphide lubricants be used for the bearing.

Pressed-out grease should be removed in order that ladders and platforms do not become slippery.

### **NOTES TO LUBRICATION OF SLEW. BEARING RING:**

The grease packing will reduce friction, seal and protect against corrosion. Therefore it is recommended to grease until a collar of grease appears all around the circumference of the bearing openings. The collar of grease prevents water, dirt and grease of the external tothing penetrating into the bearing race.

Grease the tothing after working or on weekends, as the grease, especially in form of sprays, need 12 hours to dry. The stipulated time for drying has to be kept. (Consult the recommendation of the manufacturer).

Shorter greasing intervals: In tropical areas, cases of high humidity, wide temperature range.

TROLLEY / HOOK SYSTEM

HOIST SYSTEM

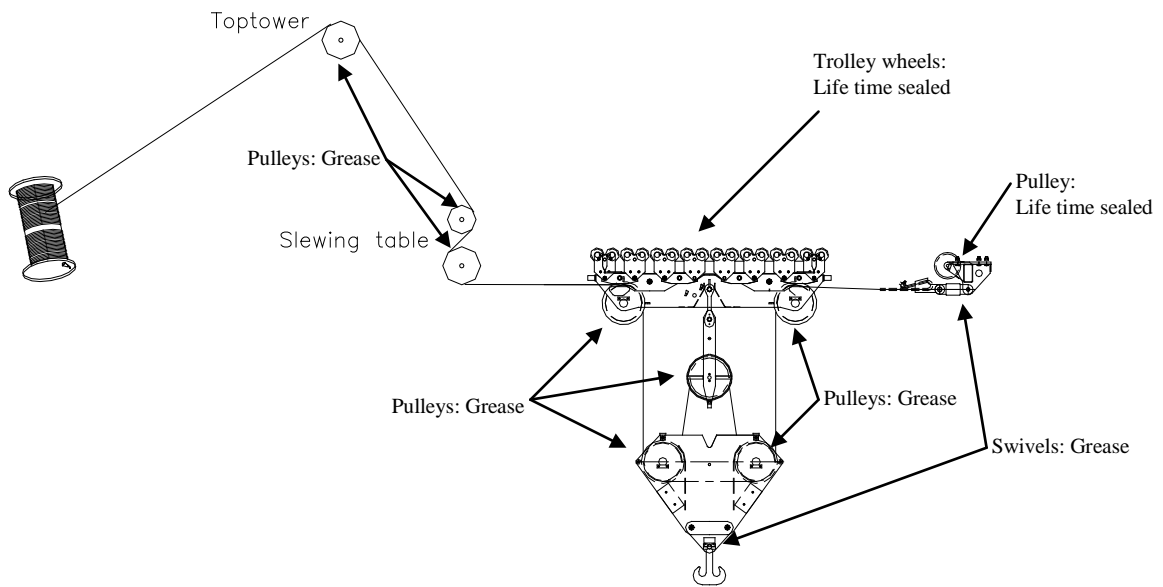

TROLLEY SYSTEM

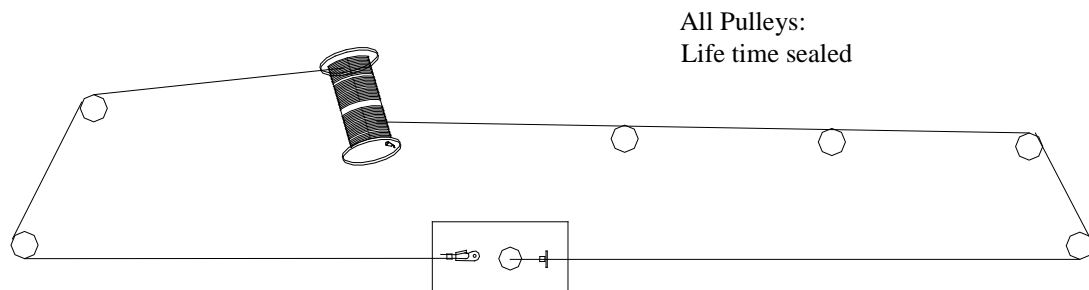

THIS DRAWING IS THE PROPERTY OF  
KRØLL GIANT CRANES A/S AND MAY  
NOT BE REPRODUCED IN WHOLE OR  
PART WITHOUT PERMISSION

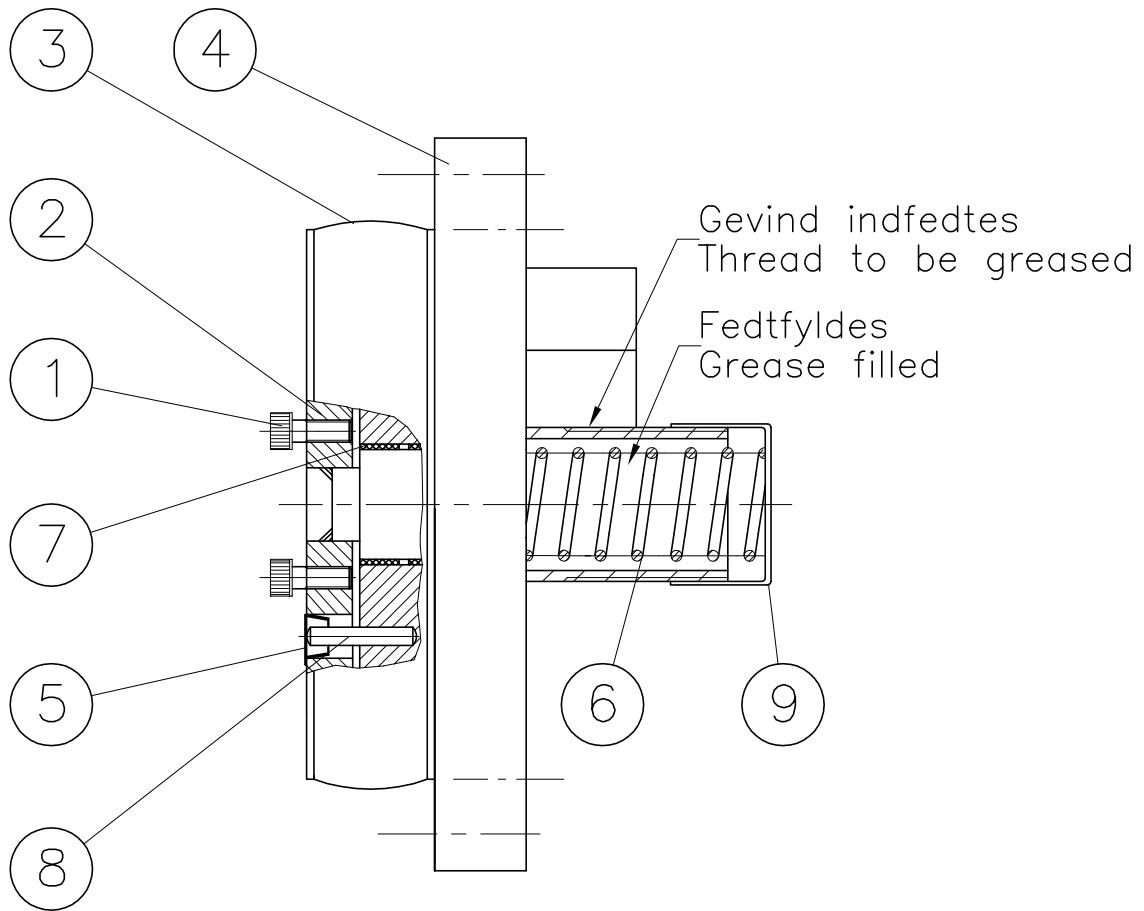

9		D.B.I. Dut		No. 42.4				Type M 50421
8	42.89505030	Ascending pipe $\varnothing 5 \times 30$			1		0.1	
7	43.00099634	Bushing	20	MB 3020 DU	2			
6	4-06.20018406	Spring			1		0.1	
5		D.B.I. Dut		No. 15 S	2			
4	C2-34.00045719	Magnet		180 Volt DC	1		8	
3	4-34.00015347	Rubber muff			1		0.1	
2	3-34.00015320	Armature			1		2	
1	42.10006014	Insex M6 x 14		10.9	4			
Pos Nr.	Tegning Nr.	Titel	Længde	Type-Kvalitet	Stk	Vægt stk	Vægt total	Bemærkninger

KONST.: 071129 JL	PROJ.	KRANTYPE	STK.	SAML. TEGN.			
TEGN.: 071129 JL		K100L					
GODK.: 071129 JL		KH100L					
ERSTATTER:	SKALA:	OVERF. AREAL:	OVERFLADE-BEHANDLING:		MATR.:		
	1:2	$m^2$			DIM.:		
ERSTATTET AF:	TOTALVÆGT:		ANT. TEGNING.:		ANT. STYKL.:		
	10,5 kg		TITEL				
OPRINDELSE:	TRANSPORTMÅL:		K-brake 180 V				
	$m^3$						
		<b>KRØLL CRANES A/S</b>			TEGN. NR.		
NORDKRANVEJ 2		DK-3540 LYNGE			C4-16.00045720-00		
PHONE: +45 48 18 74 00		FAX: +45 48 18 88 07					

A

B

C

D

E

F

G

# **CRANE ROPES**

## **MAINTENANCE INSTRUCTIONS**

**(DIN 15020)**

## MAINTENANCE INSTRUCTIONS FOR CRANE ROPES

### 1. STORAGE

Wire ropes must not have suffered corrosion, rusting, damage or severe contamination with dirt when they are installed. Ropes must therefore be stored in a dry place and moisture condensate prevented from forming on non-galvanized ropes.

### 2. INSTALLING

When the wire rope is pulled off a reel or uncoiled from a ring, it must neither be twisted more tightly nor untwisted, or else the structure of the rope will be damaged and kinks or loops will form.

We recommend setting up reels on a shaft suspended between trestles, and leading the rope as directly as possible from the reel to the winch drum on the crane. One man should remain by the reel to brake it so that the rope is always slightly taut. Ropes supplied on rings must be uncoiled on the ground.

Before installing a wire rope, make sure that it fits the grooves on the drum and that the diameter is correct for the pulley grooves.

Prevent the rope from dragging across the ground before it is installed, or else the impregnation will pick up dust and dirt. This will damage the rope and cause premature wear. If there is any risk of the rope being dragged across sharp-edged items of the metal structure during installation, cover or pack the danger areas thoroughly with wood.

When replacing a rope, ensure that the new rope is of the same pattern and strength rating as the previous rope when it was new. The end fastenings of the new rope must also be identical with the old ones.

Before running the winch after renewing a rope check that the rope has been wound on correctly and is lying securely in the drum and pulley grooves. Make the first few trial movements at light load only.

If the rope is wound in several layers on to the drum, the layers underneath must be adequately preloaded with at least 1% of the rope's breaking strain or, for heavy duties, 10% of the ropes pull for the anticipated load. This will provide a firm base for the upper rope layers during operation, so that they do not cut into the lower layers or damage them.

If several hoisting ropes are used in pairs, the left-wound ropes must be on the drum with the grooving cut in the right-hand pattern, and vice versa.

### 3. MAINTENANCE

Wire ropes need regular maintenance, with particular care devoted to rope drives subject to severe loads.

Ropes must lubricate at regular intervals, in particular where they pass round pulleys and drums. The actual intervals will depend on local operating conditions, but subsequent lubrication is normally recommended at least every 200 hours of operation. In special circumstances – extreme weather, sea air etc. – it may be necessary to reduce the intervals between lubrication routines.



The lubricants must be compatible with those already on the ropes. Oils are normally superior to grease because they can penetrate the interior of the rope, but some greases contain additives to aid penetration. Please refer to the Table of Lubricants for details of the greases and oils we recommend.

Ropes which move in operation should be cleaned at intervals, since the mixture of dust and residual lubricant which otherwise forms can prevent fresh lubricant from penetrating the rope.

Lubrication is also important as a means of preventing corrosion. Fixed ropes should be greased or painted to protect them against corrosion or rusting.

If operating circumstances make it impossible to lubricate a rope once it has been installed, its working life will be reduced and it should therefore be inspected at more frequent intervals.

#### 4. ROPE INSPECTION

At regular intervals, wire ropes should be inspected by trained and skilled personnel to ensure that they are still serviceable. Inspect at more frequent intervals in the first few weeks after installing a new rope, and also when the first broken strands are detected or if the rope was subjected to unusually high loads.

When starting up again after a lengthy shutdown period, and after any damage has occurred which could possibly have been associated with the rope, carry out an additional inspection.

Examine sections of rope which pass over pulleys and the end fastenings of the ropes with particular care.

Replace damaged wire ropes in good time. The number of broken strands permitted is governed by local or national regulations. Remember that some time will normally elapse before the first broken strands occur, but that their number will then increase rapidly.

Wire ropes must also be replaced if:

- structural changes have occurred so that the rope diameter is 15% or more below its original nominal diameter over a fairly long distance.
- corrosion or rusting has caused the rope diameter to be 10% or more below the nominal diameter.
- the rope diameter is 10% or more below the nominal diameter on account of wear.
- severe deformation of the rope structure is visible, such as expanded “baskets”, severe corkscrew deformation, severe wire strand loops, loose strands on account of corrosion or wear, loops and twists, mechanical damage, severe kinks or necking.

Cast-in or potted rope ends must be checked regularly for strand breakage and corrosion where the rope emerges from the cast metal.





Rope end fastenings using press-fit sleeves must be checked for strand breakages adjacent to the sleeve, cracks in the sleeve material and slippage of the wire rope through the sleeve.

For further inspection requirement, refer to German Industrial Standard DIN 15 020 Part 2.

**NOTE:** We cannot guarantee faultless operation of the crane if ropes are used other than those specified by us.

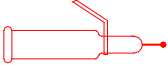
# SMØRING / LUBRICATION

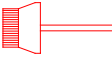
## SMØRESKEMA LUBRICATION CHART

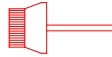
SMØREMIDDEL LUBRICANT	+ 40--- + 30° C	4				2	12	7/9		5	7/9		3	4	
	+ 45 --- + 20° C	3				1								3	
POSITION		A	B	C	D	E	F	G	H	J	K	L	M	N	O
METODE METHOD															
MAX. PERIODE I UGER	KONTROL CHECK					1	4	1	4	1			12	52	4
	SMØREINTERVAL LUBE INTERVAL	4	12	25	1						12				*
MAX. PERIOD IN WEEKS	SKIFT CHANGE					52				52					
MAX. ANTAL DRIFTSTIMER	KONTROL CHECK					100	100	50	100	20		8	250	2500	100
	SMØREINTERVAL LUBE INTERVAL	100	250	1250	20						250				*
MAX. NUMBER OF OPERATION HOURS	SKIFT CHANGE					1000				2500					
	EVT. SMØRING LUBE IF REQUIRED							•	•			•	•	•	
* EFTERFYLDES, NÅR FYLDMÆNGDEN ER NEDE PÅ CA. 1/9 AF MAXIMUM. REFILL WHEN APPROX. 1/5 OF THE MAX. FILLING IS LEFT IN THE TANK.															

### DANSK - BEMÆRKNINGER

De fleste rulningslejer er livstidssmurte og kræver ingen smøring.

**Pos. E:** Første skift af olie i gearkasser foretages efter 12 uger eller 250 driftstimer.  
Gearkasser skal udskylles med skylleolie, før ny olie påfyldes.

### ENGLISH - NOTES:

Most ball/roller bearings are lifetime sealed and require no greasing.

**Pos. E:** First change of oil in gearboxes after 12 weeks or 250 operating hours.  
Clean out the gearboxes with flushing oil before filling in new oil.

SMØREMIDLER :  
LUBRICANTS : INFO NO.: 2102

**LUBRICANTS**  
**EUROPEAN TYPE DESIGNATIONS**

REF.	SHELL	GULF	ESSO	MOBIL	TEXACO	CASTROL	MOLUB-ALLOY	SPECIAL	
1	Omala 150 Multigrade 85W/140	EP Lube S 88 MP GO 90	Spartan EP 150 GO GX 80 / 90	Mobilgear 630 Mobilub HD 90	Multigear Lube EP 80W/140	Alpha SP 220 Hopoy LS 90	Gear Oil 90		
2	Omala HD 150 Multigrade 80W/90	Mechanism LP55 Harmony AW 54	Spartan synthetic EP220	Mobilgear SHC 629 Mobilub HD 80	Multigear Lube LP 80W/90	Hopoy Light 80 Hopoy C 80W/90	Gear Oil 80		ONLY
3	Alvania EP 2 Retinax A	Gulfcrown Grease No. 2	Beacon EP 2 MP Grease	Mobilplex 48 Mobilgrease 77	Multifak EP 2	APS 2 Grease LM Grease	BRB 572	Lubral MP 2	
4	Aero Shell Grease 14		Beacon EP 2 MP Grease	Mobilplex 48	Regal AFB 2 Multifak EP 2	APS 2 Grease LM Grease	BRB 572-1		Slewing Ring & King Pin assemb.
5	Tellus T37	Mechanism LP 47 Harmony AW 48	Nuto HP 32	Mobilfluid 125	Rando Oil HDAZ-32	Hyspin AWS/AWH 32			
6	Tellus R5					Hyspin VG 5			
7	Kuggspray Kugggrease	Lubcote Spec.	Surret Fl. 30	Mobiltac 81	Texclad Spray	Grippa 60S Grippa 33S	OG Grease 882 EP Medium	Molykote W Ferro Gard Sp. Medium 12%	Winter
8	Tonna T68	Gulfway	Millcot K 55	Vectra No. 2	Way Lube 68	Magna BD 68 Non Creep 26	MWO-30		
9	HD Grease 221	Gulflex Moly				Molytex EP 2	OG Grease 882 EP Heavy	Molykote X Molypan K	Summer
10								Ferro Gard Molymax	
11	Spirax HO Multigrade 85W/140				Multigear Lube EP 80W/140	Hypoy C 85W/140 Hypoy C 80W/140	Gear Oil 140		
12	Grease S 3655	Gear Grease 0 *)	Fibrax 370 *)	Mobilplex 44 *)	Marfak 00 *)	DK Grease *) Alpha Gel	Grease 0 *)		
13	HD Grease 221					Molytex EP 2	MS 3 Grease Impervia MO		
14								Silicon Grease	

On delivery the cranes are lubricated with SHELL.

\*) Must not be mixed with SHELL GREASE S 3655

**LUBRICANTS**  
**EUROPEAN TYPE DESIGNATIONS**

REF.	SHELL Before 820101	CHEVRON	BP	ELF					
1	Spirax HD 90	Universal Gear lube 85W/140	Hypogear 85W/140EP	Tranself B 85W/140					
2	Spirax HD 80	Universal Gear lube 80W	Hypogear 80W/90EP	Tranself B 80W/90					
3		Polyurea EP Grease 2	<b>Energrease LS-EP 2</b>	<b>Epexa 2</b>					
4		Polyurea EP Grease 1	Energrease LS-EP 1						
5	Tellus T27	EP Hydraulic Oil 32 HV	Energol SHF 32	Hydrelf 32					
6	Tellus C5		Energol HP 5						
7			Energrease OG						
8		Way Oil 68	Maccurat 68	Resto 68					
9		Pinion Grease MS	Energrease L 21 M						
10									
11	Spirax HD 140	Universal Gear lube 85W/140	Hypogear 85W/140EP	Tranself B 85W/140					
12		GP Grease 0 *)	Energrease FG 00-EP						
13			Energrease L 21 M						
14									

On delivery the cranes are lubricated with SHELL.

\*) Must not be mixed with SHELL GREASE S 3655